

HIGH TORQUE HYBRID STEPPING MOTOR SPECIFICATIONS

General specifications		Electrical specifications	
Step Angle (°)	1.8	Rated Voltage (V)	2.8
Temperature Rise (°C)	80 Max (rated current, 2 phase on)	Rated Current (A)	2.0
Ambient temperature (°C)	-20~+50	Resistance Per Phase(±0%Ω)	1.4 (25°C)
Number of Phase	2	Inductance Per Phase(±20% μ H)	1.4
Insulation Resistance (MΩ)	100 Min (500VDC)	Holding Torque (Kg.cm)	3.9
Insulation Class	Class B	Detent Torque (Kg.cm)	0.21
Max.radial force (N)	75 (20mm from the flange)	Rotor Inertia (g.cm ²)	120
Max.axial force (N)	15	Weight (Kg)	0.45

● Pull out torque curve:

VOLTAGE: 30VDC, CONSTANT CURRENT: 2.0A, HALF STEP

● Wiring Diagram:

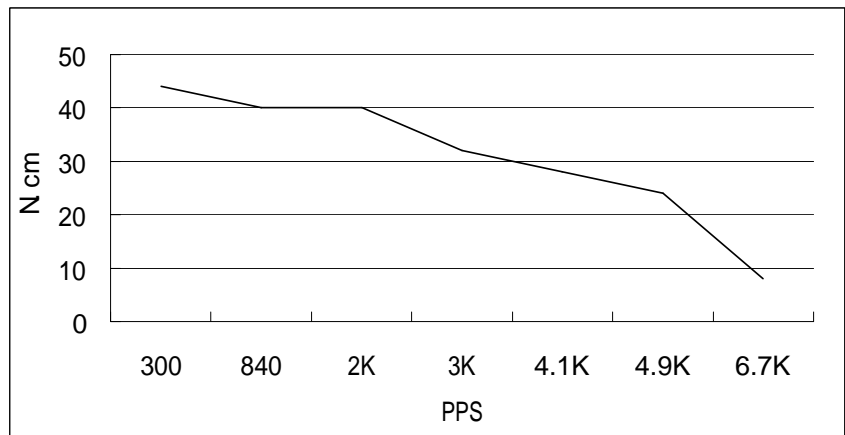
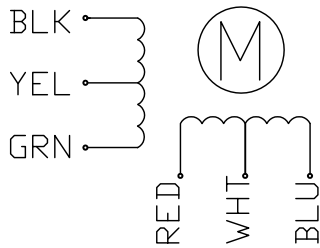

● Dimensions:
(unit=mm)

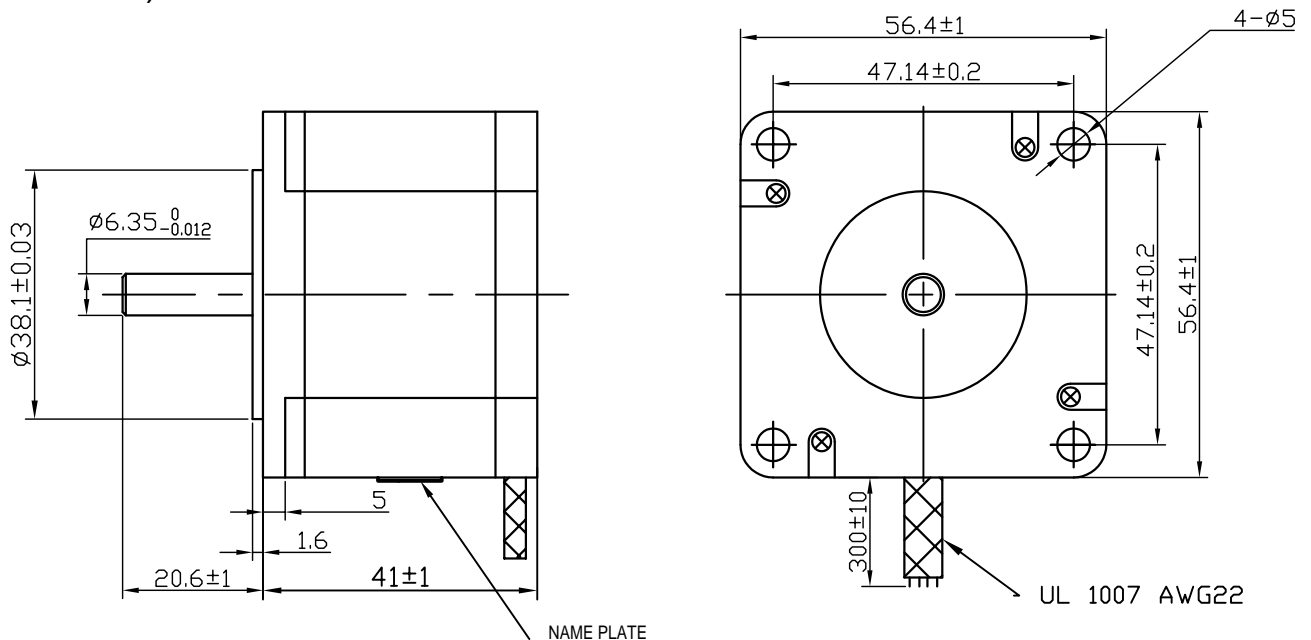

△					SY57STH41-2006A	TECHNICAL CONDITIONS
△						
REV	REVISIONS	DESCRIPTION	BY	DATE	CHANGZHOU SONGYANG MACHINERY & ELECTRONICS NEW TECHNIC INSTITUTE	
DRAW	王凯					
CHECK						
APPROVE						